

Wireless Switchgear with Safety Function

With the ESALAN Wireless Systems the Schmersal Group extends its range of switchgear and systems for the protection of man and machine. A safety-oriented radio link supersedes the traditional cable connection.

Thus, for example, safety-oriented and operational signals of control devices, as are typically to be found in mobile control housings, can in future be transmitted without the need for wires. The safety-related quality of signal processing of the SAFETY-STOP control devices, 3-phase enabling switches or other control devices with an effect comparable to EMERGENCY STOP* corresponds to the control category 3 and, following BG prototype testing (refer to page 12), control category 4 to EN 954-1.

However, other safety-oriented switchgear and protective devices, such as the 3-phase foot switch or two-hand switches, also come into question as equipment for the ESALAN Wireless Systems.

Under consideration of the size of the radio electronics (2 printed circuit boards, each measuring 15 x 65 x 40 mm, 1 x transmission module, 1 logic module) and the technical data and system features, the other safety switchgear from the Schmersal range and also other mobile control devices, also on OEM basis, can be equipped with the radio electronics. Further information is available on request.



* Refer also to "Definition of terms" in the box



Definition of Terms

Even if control devices to bring to a standstill in an emergency are also usually necessary here, according to IEC EN 60204-1 Item 9.2.7, such devices with wireless control systems *may not be marked or labelled as EMERGENCY STOP control devices even if the stop function may be a function to bring the machine to a standstill in an emergency.*

The intention of the standards boards is to avoid confusion because EMERGENCY STOP devices must be effective in all operating modes of a machine, whilst wireless control systems are frequently only activated in special operating modes.

Against this background no traditional EMERGENCY STOP devices are offered in the ESALAN Wireless System (features (1) operating head, mushroom or palm shaped, (2) colour red or similar RAL 3000, (3) yellow background) but similar solutions that cannot be confused under consideration of the abovementioned features.

The term “EMERGENCY OFF” is not used at all in this catalogue because ISO EN 13850 will soon replace the current EN 418 “EMERGENCY OFF Control Devices”. The words “SAFETY-STOP control devices” will be used, thereby complying with international features. New test requirements placed on the devices are already contained in IEC EN 60947-5-5 (VDE 0660 Part 210). ISO EN 13850 also takes over the provision pursuant of Item 9.2.7 from EN 60204-1 under the key word “reduction of possibilities of confusion”.

Application

From the point of view of application the ESALAN Wireless Systems are particularly aimed at the benefits of wireless technology in the HF-critical factory environment.

In contrast to free field applications and applications similar to free field ones, e.g. in warehouses, the operation of a radio-based system is not without its problems. This applies particularly under factory environment conditions, as it is precisely here that all HF-critical disturbing influences, such as attenuation, reflections, absorption, diffusion, deflections, refraction and interference have such a particularly strong impact on a system of this nature.

For this reason, the availability of a radio link was attributed as much as significance in the design and development of the ESALAN Wireless System as the safety requirements.



Advantages

In complex machinery, automatic production systems and plants, ESALAN Wireless Systems are used

- to improve machine availability by preventing damage to loose cables;
- to improve productivity because operators can move more freely without wires;
- to save costs
 - through the replacement of a number of discretely wired decentralised operating stations for special operating modes, as

can frequently be found in large machines, e.g. printing machines, by one (or only a few) ESALAN Wireless System(s);

- to save costs
 - through the replacement of trailing cables, slip rings etc. that are subject to wear and tear;
 - in the retrofitting and modernisation of machines.



Mobile wireless controls

As a complete solution, an ESALAN Wireless System as a wireless control unit, consists of the following:

- a **mobile control housing** with integrated transmission electronics including storage batteries and dual band transmitting antenna (see loc. cit) fitted with an EMERGENCY STOP control device, optionally with a 3-step enabling switch or another control device with an effect comparable to EMERGENCY STOP as well as up to four other control devices for movement signals;
- a **programmable analysis and control device** including receiving electronics and two antenna sockets, with six safety-oriented semiconductor outputs,

three signalling outputs and – in addition to the radio-based inputs, four additional safety-oriented inputs (details on control category in accordance with EN 954-1: see Section “System programming”);

- two 1/2-Lambda-**receiving antennas** (1 x for 433 MHz, 1 x for 869 MHz) for external mounting of up to a distance of 30 metres from analysis device plus connection cables;
- a **charger** (not shown);
- and corresponding commissioning and programming **software** including **operating instructions**.



Measures guaranteeing availability

The following are among the most significant measures to guarantee availability in the ESALAN Wireless Systems:

- a redundancy of the radio link,
- a fault tolerance of 7 in respect of messages not received or inconsistently received,
- the so-called antenna diversity,
- the dimensioning of the system
- particularly effective HF filter mechanisms

etc.

All measures serve to control the interference that affects an HF system which is preferably operated in a factory environment and in a closed circuit current principle (refer to Page 8) due to compelling disturbing influences.

Of relevance here are on the one hand the influences already mentioned resulting from attenuation, reflection, absorption or interference but also from physically related higher bit fault probability which is always to be expected in wireless systems.

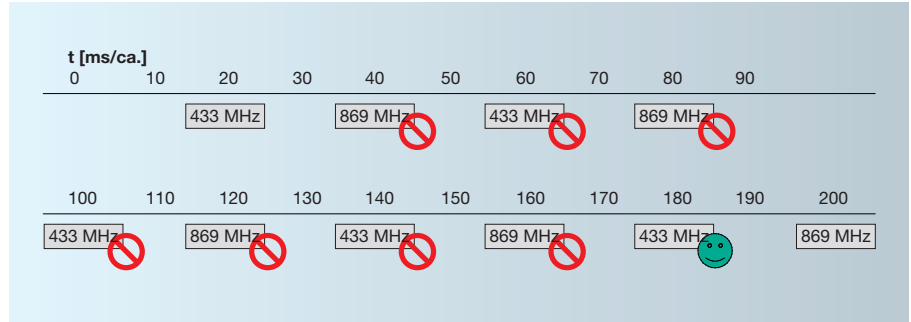

Alternately mode of operation at 433 MHz and 869 MHz-band (see above) with fault tolerance 7 with no messages received or inconsistently received.

Dual-band system

ESALAN Wireless Systems are operated either in the licence-free 433 MHz band or the 869 MHz band. The classic redundancy concept realised here of operating the system with two radio links as a so-called dual-band system serves in particular to considerably increase the reliability of the system. Both bands are operated under consideration of a so-called duty cycle of 10% as already prescribed by law for the 869 MHz band and for the 433 MHz band as conceived as a future requirement.

Fault tolerance 7

Against the safety-related background of increased requirements placed on data integrity, the measures contributing to guaranteeing availability also include a fault tolerance of 7 with no messages received or inconsistently received.

This means the system reacts only when 7 messages are missing or are transmitted "damaged".

If, by contrast (refer to Figure above), an eighth message is transmitted correctly again, the ESALAN Wireless System carries on working (fault tolerance of 7).

The high requirements placed on the data integrity of a safety-oriented radio link results in particular from standard EN 60 870-5-1 and the test principle GS-ET 26 "Bus Systems for the Transmission of Safety Relevant Messages" of the Berufsgenossenschaft der Feinmechanik und Elektrotechnik, Cologne (refer also to page 9).

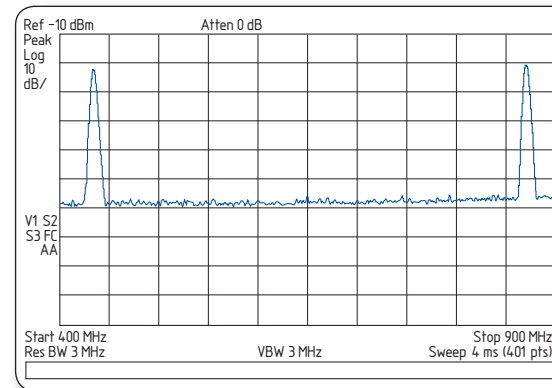

Frequency bands 433 MHz and 869 MHz (recorded with spectrum analyser)

Background for these requirements are the protective objectives to prevent an unintended command and to guarantee a clear assignment of mobile control housings and analysis and control devices (refer also to pages 11 and 21 in this respect).

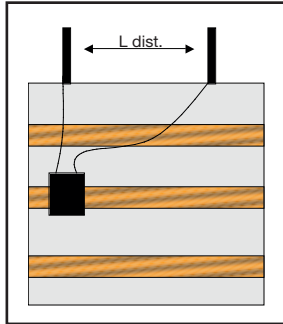

Antenna diversity to avoid "dead spots" and field strength fluctuations in the case of using moving mobile control housings.

Antenna diversity

The third important measure to guarantee the so-called antenna diversity with two antennas (1 x for 433 MHz, 1 x for 869 MHz) on the receiver side which can be set up up to 30 metres away from the analysis and control device. Decentralised mounting means that the system can be adapted to the HF conditions at the respective operation site of an ESALAN Wireless System.

If so-called radio shadows or field strength fluctuations exist, the feature of antenna diversity enables the two receiving antennas to be positioned such that an optimum radio link can nevertheless be achieved (see box).

In this respect the option exists to connect several receiving antennas per band by means of a power splitter (upon request), i.e. to cascade the 433 MHz and 869 MHz antennas in a type of parallel circuitry.

Ideal radio connection

In order to achieve an ideal radio connection, transmitter and receiver (mobile control housing and the receiving antennas) require a "virtual visible connection". This is an ellipsoidal free space around the visual axis between transmitting and receiving antenna similar to a "Fresnel Zone". Without wishing to delve deeper into the technicalities of HF and the possibilities of mathematical calculation (refer to the ESALAN Wireless Operating Instructions in this respect), adequate radio quality for a frequency band is to be assumed if an HF free space of approximately 1.5 metres exists at the head of the ellipse between transmitting and receiving antennas.

In this connection, HF free space means that no solid shielding elements (such as steel plates, thick reinforced concrete walls, fine-meshes or similar) interrupt the ellipse of the "virtual visible connection" in its entirety.

In other words, the requirement of the "virtual visible connection" may not be

understood in its absolute sense. However, it should be essentially free from objects shielding the radio waves or causing interference with the direct radio waves.

"Interfering transmitters" are to be avoided at all events.

However, since this restrictive requirement on "virtual visible connection" cannot be guaranteed throughout (thought is given here in particular to the mobile use of radio systems in factory environments), the benefit of ESALAN Wireless Systems is shown particularly from the aspect of optimum radio connection, i.e. the fault tolerant mode of action in the dual-band system, and therefore the advantage of antenna diversity (and antenna cascading where applicable).

Particularly in view of these features it can be assumed that the "virtual visible connection" will always exist for at least one of the two radio links if the system is arranged intelligently, thereby minimising the risk of system interference.

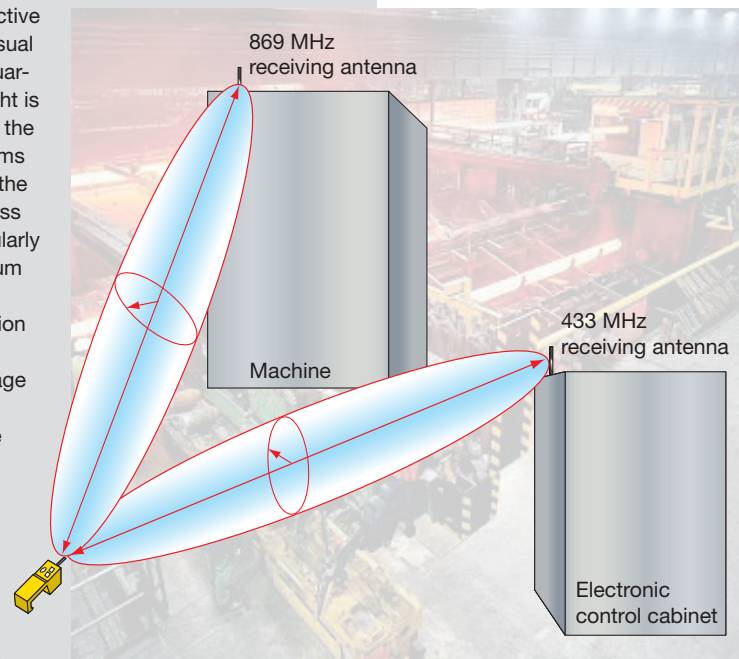

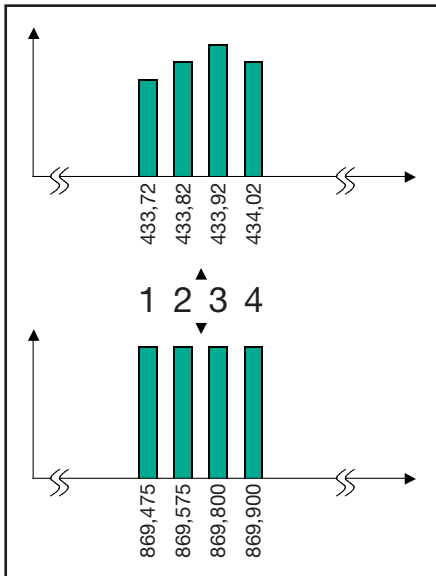

Selectable channel pairs within the bands

System dimensioning

The system dimensioning features include the following

- an adjustable free field range of up to 250 metres, i.e. with respect to use in a factory environment, there are sufficient reserves if the ambient conditions were to restrict the range;

- a nickel metal hydride storage battery (NiMH) with an operating duration of at least 50 hours;
- a battery charge display available as signalling output in the analysis and control device;
- a powerful battery charger (with dU/dt charging process with fast charging features and protection of the storage battery from overcharging).

Filter mechanisms

Particularly narrow band filter mechanisms, including the suppression of GSM bands (mobile telephony) by means of band/low pass filters, are also additional measures to increase availability.

Channel selection

The filter mechanisms also permit four different channels to be set within the two radio bands in order to avoid the ESALAN Wireless Systems affecting each other if several systems work within close proximity or if other radio



Attention: Despite all measures which, when combined, exceed the usual level of technology for industrial radio systems, HF interference cannot be ruled out under particularly unfavourable operating conditions of an ESALAN Wireless System. If it can be justified for safety reasons, we therefore recommend the realisation of signal processing of safety-oriented stop commands from a combination of the stop categories 0 and 1*.

* STOP category 1 to EN 60 204-1: controlled stopping i.e. the energy to the machine drive units is maintained to achieve the stop. The energy is only interrupted once the stop has been achieved.
 STOP category 0 to 60 204-1: uncontrolled stop, i.e. the energy to the machine drive units is discontinued immediately.
 Realisation suggestion: STOP 0 for a controller release (or similar) and STOP 1 for the power contactor (or similar).

systems operating at the 433 MHz or 869 MHz frequencies disturb the ESALAN Wireless Systems.

A large number of channels is not available within the scope of licence-free bands due to statutory regulatory provisions (see “options” however).

Options

All measures to guarantee availability as realised in the ESALAN Wireless System are based on worst case considerations in use which need not necessarily exist in the different applications.

Since this aspect of overdimensioning was taken into consideration at the outset in the design of the ESALAN Wireless Systems, other system versions (if used in less favourable environmental conditions) also permit other functional and technical features (upon request).

- For example up to 14 ESALAN Wireless Systems can be operated in direct proximity if a radio frequency, with a fault tolerance of 3, guarantees adequate system availability. Increasing the fault tolerance is not advisable because this leads to an extension of the safety-oriented reaction time (refer to Page 12).
- Reducing the reaction time of a standard 200 ms (refer to loc. cit.) is possible if systems working in dual-band operation are set to a fault tolerance lower than 7 or under certain circumstances to be examined in individual cases may be operated with a higher duty cycle than 10%.

Safety-related features

With respect to the different relevant standards, ESALAN Wireless Systems are characterised by several safety-related features.

- **The so-called closed-circuit current principle according to which the radio link is operated is one of the most elementary safety-related principles and is set out in a host of standards as a basic requirement on the design of safety circuits (e.g. in EN 954-1/-2 etc.)**



Message transmission in the "closed circuit current principle"

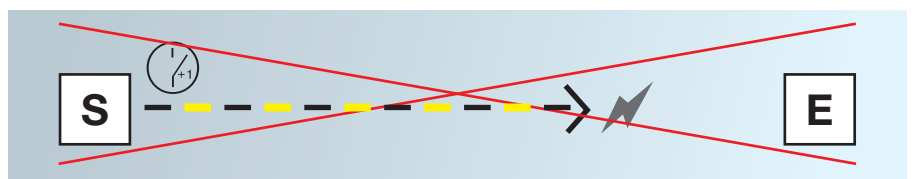

Message transmission in the "working current principle" (not admissible for safety-oriented machine controls)

In the case of ESALAN Wireless Systems, closed circuit current principle means that the radio link of both bands is constantly active between transmitter and receiver under consideration of the statutory duty cycle (refer to box "ON period"). An SAFETY-STOP command or similar results in a safe interruption of the radio link.

In contrast to wire-based safety circuits, the term closed circuit current principle is to be considered as a dynamic working principle with regard to HF, i.e. the signals are pulsed at intervals of approximately 25 ms per band on a constant basis (refer to the figure above and page 5).

On the basis of the analogous application of the closed circuit current principle it is ensured that the processing of an EMERGENCY STOP signal or similar is not based on the (safety-related inadmissible) expectation that the corresponding signal can be transmitted without disturbance and fault.

The ON signals (useful signals) are transmitted within the scope of the constantly transmitted messages in the closed circuit current principle (refer to page 9, "Message Structure").

"ON period"

In addition to the advantage of saving energy, the dynamic working principle is a mandatory legal requirement in the 869 MHz band in which the observation of a so-called duty cycle (one could also speak of an ON period) of maximum 10% is required so that other HF systems can be operated in the breaks (a duty cycle regulation is in preparation for the 433 MHz band).

- The radio link itself is viewed as a safety oriented serial data bus based on the testing principle for the testing and certification of “bus systems for the transmission of safety-relevant messages” GS-ET 26 of the Berufsgenossenschaft der Feinmechanik und Elektrotechnik, Cologne, under consideration of a higher bit fault probability of wireless systems.

This testing principle deals particularly with measures to avoid any conceivable transmission errors in serial bus systems, i.e. errors which could have a safety-critical effect on data integrity due to (data) repetition, loss, insertion, wrong sequence, corruption or delay.

All measures were therefore realised in the ESALAN Wireless System as in the ESALAN Safety Field Bus System and as tested and certified by the Berufsgenossenschaftliches Institut für Arbeitssicherheit BGIA, St. Augustin, for the control category 4 to EN 954-1.

With an increased hamming distance, the measures also take into consideration a higher bit fault probability which is assumed to be 10^{-2} within the framework of a safety-related worst case analysis (vs. 10^{-5} for cable-based systems).

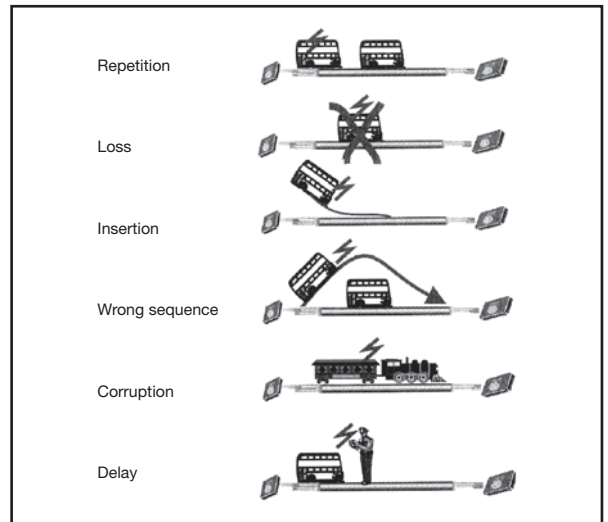

In addition to the necessary safety-related features such as identifier, counter and CRC, as well as the bits for the transfer of useful signals, additional measures have also been taken in a message serving data integrity of relevance to availability.

Pream.	ID	IO	CNT	Addition	CRC
Pream.:	Preamble				
ID:	Identifier of the useful signals				
IO:	Status of the useful signals				
CNT:	Counter 00 ... 11				
Addition:	Additional data				
CRC:	Checksum				

Length of message: 14 bit
 20 bit
 8 bit
 4 bit
 4 bit
 22 bit
 Length of message: 72 bit

Message structure

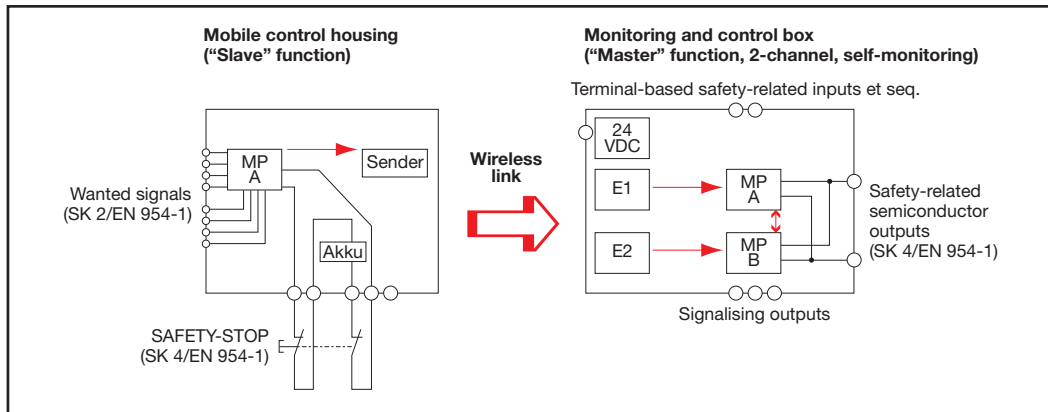

Safety-related elementary diagram of ESALAN Wireless Systems

- From an overall point of view the hardware and software of ESALAN Wireless Systems are based on IEC EN 61 508 (PFH values and SILs: refer to page 35).

Translated into the requirements of EN 954-1, the concept of ESALAN Wireless Systems corresponds to control category 4. Until such times as the BG prototype test has been performed (refer to Page 12), systems are placed on the market with the specification of control category 3 to EN 954-1.

The system structure is a type of master/slave principle such that the electronics in the analysis and control device have two channels with self-monitoring and the electronics in the transmitter in the mobile device are operated on one channel. With respect to the messages transmitted uni-directionally from the transmitter to the receiver, the interaction of both assemblies is based on a combination of time and consistency expectations in the analysis and control devices.

This mode of operation gives the ESALAN Wireless System the special safety-related advantage that in the event of a safety-oriented STOP signal, the supply voltage of the storage battery between the storage battery and the electronics in the mobile control housing is interrupted positively and through two channels. Therefore no more messages can be sent so that the watchdog function in the analysis and control device reacts with a safety-oriented shutdown of the enabling paths.

The useful wanted signals transmitted from the transmitter to the receiver comply with control category B to EN 954-1 (state of the art) in terms of their safety-related quality i.e. they have not been supplemented by additional safety-related measures.

This does not apply to the so-called START signal with which an ESALAN Wireless System (refer to page 21) is actively switched. This signal is processed in the analysis and control device with a safe edge detection and therefore corresponds to control category 2 to EN 954-1.

Within the sense of the HF regulations, ESALAN Wireless Systems satisfy the requirements of ETSI EN 300-220-1 (confirmed by a module release of CETE-COM GmbH, Essen).

With respect to the EMC requirements, the more stringent standards in EN 61 496-1 are satisfied for AOPDs.

Special requirements placed on wireless control systems to EN 60204-1

ESALAN Wireless Systems also take into consideration the following special requirements in EN 60204-1 Item 9.2.7 for wireless control systems:

- Unauthorised use
- Unintended commands
- Clear assignment

Similarly, all additional requirements specified in EN 60204-1 (data integrity, hardware/software, environmental influences etc.) are taken into consideration (description; see loc. cit.).

- An **authorised access** can be realised via the safety-oriented inputs in the analysis and control device, for example, via key operated selector switches or other access authorisations and/or linked to other logical conditions.
- The avoidance of an **unintentional command** serves to tune the START signal in compliance with control category 2 to EN 954-1, using which the ESALAN Wireless Systems are actively switched.
- The clear **assignment of transmitter and receiver** is performed via an individual identifier which is pre-programmed by the factory in the mobile control device (in the mobile part) safe from manipulation and which must be programmed during the commissioning of the system in the analysis and control device. This measure ensures that only one mobile part can have an effect on an analysis and control device or vice versa that several mobile parts cannot have an effect on one analysis and control device or one mobile part on several analysis and control devices.
- A different **identifier management** (on request) may be necessary in certain applications. In these cases it is the responsibility of the user to satisfy the requirements of EN 60204-1 Item 9.2.7 by equivalent measures.

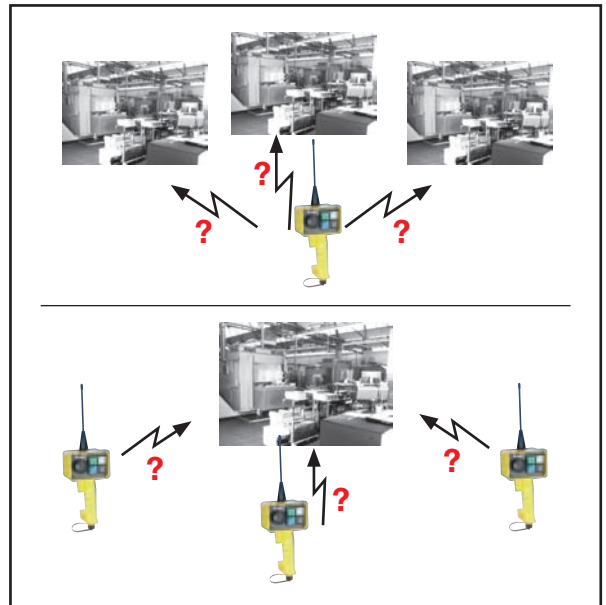

Systems risks to be avoided safely



Attention: It is not possible to restrict the area of action using the ESALAN Wireless Systems. The user must ensure by means of organisational measures and special instructions to authorised operators that a system is not operated thoughtlessly. An installation in accordance with cellular aspects is recommended.

It must in particular be ensured that in special operating modes (in the case of inactive protective devices) hazardous movements are initiated and operated exclusively from the visible area.

The “automatic operating mode” may not generally be initiated by a wireless control system.

Safety-related reaction time

The safety-related reaction time of the ESALAN Wireless System, i.e. the time between the change in signal at the input and a change in signal at the output is

- max. 200 ms in the case of radio-based inputs and
- max. 50 ms in the case of discrete inputs at the analysis and control device

By comparison: for radio-based STOP signals in crane control systems a maximum of 550 ms applies and a maximum of 4.0 s for railway applications.

In mechanical engineering applications the above mentioned reaction time of max. 200 ms is admittedly relatively long but tolerable for a large number of applications in connection with hand-actuated control devices. It is possible to reduce the reaction time with a reduction in the fault tolerance 7 (refer to Page 7, "Options") and/or other measures. Additional information: on request.



Attention: Safety distances must be checked under consideration of EN 999 (access speed 1.6 m/s) and the dynamism of the start-up behaviour of hazardous movements with respect to the reaction time of 200 ms of the radio-based signals. Additional measures may have to be taken.

ESALAN Wireless Systems are not suitable in connection with highly dynamic drives.

Prototype tests



In Vorbereitung

- **Functional safety:** On the basis of a concept approval dated 03.11.2004 by the testing office Maschinenbau, Hebezeuge, Hütten- und Walzwerksanlagen (MHHW) in the BG-Prüfzert, a prototype testing of the ESALAN Wireless System to control category 4 in accordance with EN 954-1 is currently in progress.

UL 508:

Currently not planned. Refer in the following to: HF Regulations.



- **HF-regulations:** The module release to ETSI EN 300-220-1 by CETECOM GmbH, Essen has already been successfully completed.

The testing refers to the following countries:

Germany, Austria, Belgium, Cyprus, Czech Republic, Denmark, Estonia, Finland, France, Greece, Hungary, Ireland, Italy, Latvia, Lithuania, Liechtenstein, Luxembourg, Malta, Netherlands, Poland, Portugal, Slovakia, Slovenia, Spain, Sweden, United Kingdom, Iceland, Norway, Switzerland



Warning: The HF-related operating licence refers exclusively to the aforementioned EU member states and the EU associated countries.

Other regulations apply in North America (US/Canada) and in Japan which do not permit the operation of ESALAN Wireless Systems (as described here). Work is currently in progress on a special North American version of ESALAN Wireless.

The legality of using the ESALAN Wireless Systems in other countries must be checked.

Safety-oriented part of a machine control system

Application

An ESALAN Wireless System is not usually intended for the automatic operation of a machine control system but for special operating modes as, for example, setting up mode, service mode or process observation.

Due to the fact that in the realisation of special operating modes, protective devices operating in automatic mode of a machine must be put out of force entirely or partly (bridged) the safety-related considerations and concepts require particular care. For example, other safety measures, as equivalent as possible, must be provided to protect the operator entrusted with the performance of work and his environment from the machine hazards that continue to exist if the protective devices are bridged. These measures will include the SAFETY-STOP control device or the enabling switch in the mobile control housing of ESALAN Wireless Systems.

Even if special operating modes may be associated with high residual risks in the handling of the machine, they are necessary in order to operate a machine correctly. Otherwise, without suitable operating modes it will happen all too often in practice that operators will tamper with protective devices in order to be able to perform the requisite work but thereby maintaining the more hazardous automatic mode of the machine control system.

In this respect, ESALAN Wireless Systems also make an active contribution to increasing machine safety when facilitating the realisation of suitable special operating modes.

Interfaces

The control-related logic operations in the ESALAN Wireless Systems required for the respective special operating modes are realised by means of an intelligent interaction between the analysis and control device and the remaining safety-related part of the machine control system.

From the point of view of interfaces, the analysis and control devices have additional inputs and outputs as well as programming options for logical operations and in this respect provide the functionalities of a small safety control system. This is a further advantage of the system.

Sequences

The operation of an ESALAN Wireless System takes several intermediate steps for safety reasons:

Usually, the automatic mode of the machine control system is reliably interrupted by means of an operating mode selector switch. The special operating mode is then enabled and the ESALAN Wireless System itself enabled via a deliberate start command. During the switchover process the machine is usually in a safe state.

For operational reasons, however, other versions of the switchover process may be possible. The safety-related aspect of deliberate and authorised handling is then to be considered by means of other measures.

The programming menus "initialisation conditions" and "system start" are available for the logic of the switchover process. The protective effect of the safety-oriented command devices in the mobile control housing is automatically generated here. Refer also to page 17.

Only those people are to be able to operate which are necessary to perform the respective work via logic operations between the safety-oriented part of the machine control and the ESALAN Wireless analysis and control device in the special operating mode. In these cases and with some exceptions, the speed and/or the travel path of hazardous movements is to be restricted.

User-related programming menus, including logical gates, are available for these logic operations. Refer also to page 16 et seq. in this respect.

Safety-related details on the design of special operating modes of a machine are frequently to be found in the respective C Standards and in EN 60204-1 Item 9.2.3 and 9.2.4.



The following is an example for incorporation in a system:

Example

- In automatic mode the contactors K_A and K_B are triggered by the safety relay module (SRB xx) of a guard. In this operating mode the ESALAN Wireless System is in an inactive state, i.e. all outputs are in OFF status.
- If a change is made in the operating mode by means of a key-operated selector switch from automatic mode to set-up mode, the energy supply to the contactors K_A and K_B is interrupted.

- At the same time the ESALAN Wireless System is switched from the inactive state to stand-by mode. All outputs are still in OFF status.
- The correct selection of the set-up mode is monitored by the analysis and control device (automatic mode = OFF, set-up mode = ON).
- After the START signal, e.g. through an input of the mobile control housing, the outputs of the ESALAN Wireless System can be activated, thereby bridging the guard.

In summary, a distinction is made between the following states in the ESALAN Wireless System:

1. Inactive state:
System is in automatic mode. All outputs of the ESALAN Wireless System are in the OFF status. It is possible to load the mobile control housing.
2. Stand-by mode:
Waiting for a START signal, e.g. from a mobile control housing (not shown).
3. Active state:
After the START signal the outputs can be activated.

Refer also to page 21.

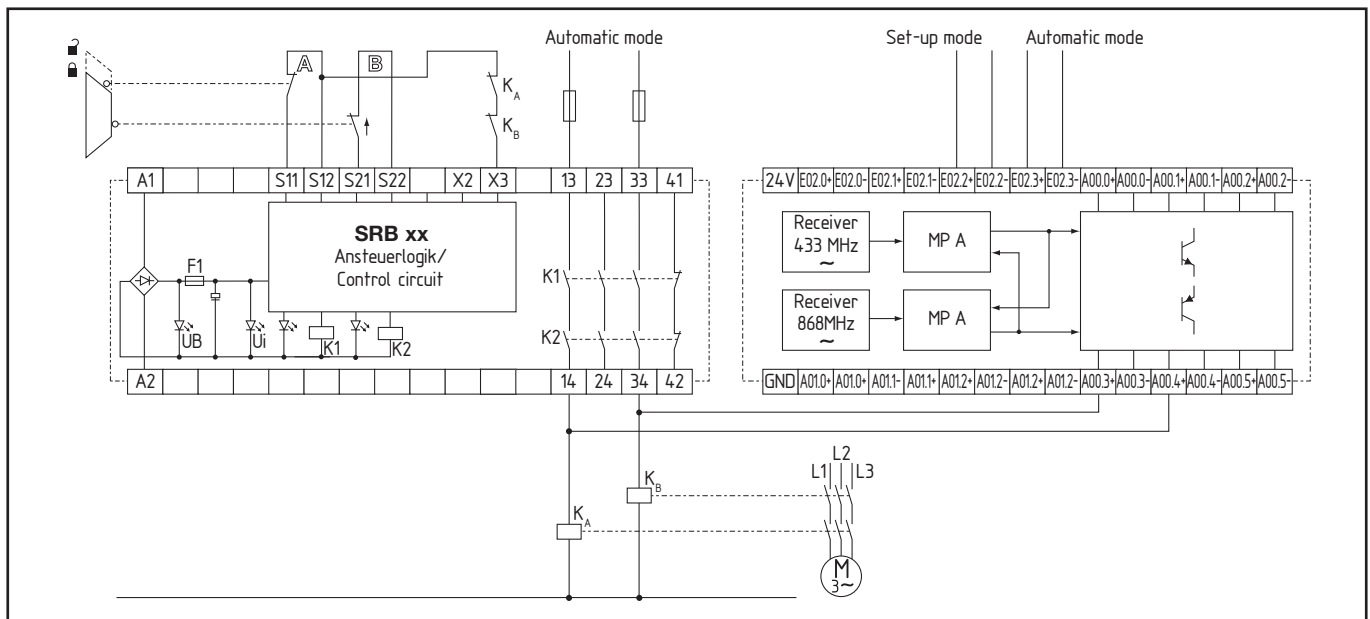

Guard door by-pass

Commissioning the system

The ESALAN Wireless Systems can be commissioned if the following conditions are satisfied:

- **System setting** (refer to page 15),
- **System programming** (refer to page 16),
- **System activation** (refer to page 21).

System setting and programming are performed via commercially available laptops or PCs with RS 232 interface and with the assistance of appropriate ESALAN Wireless software.

Setting the system

The following are to be set in the analysis and control device and in the mobile control housing:

1. the identifier
2. the required transmission performance
3. any channel selection.

In respect of 1: identifier setting

The identifier is located on the type plate of the mobile control housing. The identifier is set in the factory and cannot be altered and is unique within the framework of a large number of possibilities.

Information:

Only one identifier can be stored as standard in an analysis and control device (refer to the requirements to EN 204-1 Item 9.2.72). If for operational reasons it is necessary to store several identifiers, a special software configuration will be required (on request) (refer also to page 11).

In respect of 2: Setting the transmission performance

When the ESALAN Wireless Systems are delivered they are set as standard with the lowest transmission performance ("min."). This is done with the idea in mind that a range is to be set appropriate to the use (Refer also to page 11), "restricting the area of action". The further steps "average - min", "average -max". and "max." (5 mW ERP) are to be set by the user if the range is not adequate. We recommend that the transmission performance be set to the minimum required by the operation or process.

Signalling output A01.0

Pre-warning signal (one of the two radio frequencies not received for >2 sec.) The operator has left the area of action or the frequency is permanently disturbed.

Signalling output A01.1

System shut-down as a result of a requirement of the safety function through permanent HF interference.

Signalling output A01.2

The storage battery power is moving towards a residual charge of approx. 5 hours. This signalling output can be incorporated, for example, in the system start (refer to programming menus) in order to ensure that ESALAN Wireless operation is only started with sufficient storage battery power.

Information:

Due to the different influential factors on the spread behaviour of high-frequency waves, it is only possible to provide range information for the ESALAN Wireless System under virtually free field conditions.

From this point of view the setting to "min." will usually lead to ranges of 10 ... 25 m if two receiving antennas are set up in the proximity of the analysis and control device (approx. 1 m). The transmission performance is to be increased if the antenna distances are greater. The signalling outputs A01.1 and A01.0 (refer to box) are most helpful when setting ranges.

For further details: refer to "operating instructions" with additional information and tips.

In respect of 3: Channel selection

If several ESALAN Wireless Systems are to operate in direct vicinity to each other, interference will result. The choice of channel therefore shuts off several systems from each other by providing a choice of 4 channels within each of the 433 MHz and 869 MHz bands (refer to page 7). A larger number of channels is not available within the framework of the two licence-free bands due to regulations (but refer to "Options" on page 7).

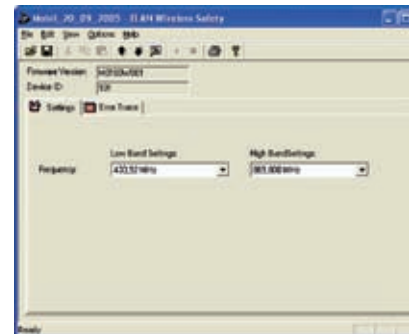
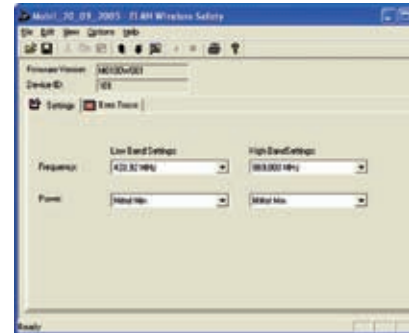

Programming the system

In order for the ESALAN Wireless System to perform control tasks the following is available in the analysis and control device (refer to page 34) under consideration of the requirements of EN 954-1 and IEC EN 61508:

- 1 radio-based input for EMERGENCY STOP and RELIABLE STOP functions
- 4 radio-based inputs for operational control functions (including a single START signal for the activation of the radio link with control category 2 to EN 954-1)
- 4 discrete inputs with control category 2 to EN 954-1 (in the case of 2-channel input circuitry = SC 4 to EN 954-1)
- 6 discrete semi-conductor outputs with control category 4 to EN 954-1
- 3 signalling outputs (refer to page 15)

Programming is performed via function and logic oriented menus, the structure of which corresponds to the wiring of safety relay modules or logical gates. It is not therefore necessary to be acquainted with a programming language to IEC 61131.

In addition to simplification or the convenience provided by the menus, a safety-related advantage is in particular that the control related logic operations behind the respective functions are already stored in the prototype tested in the case of the function-oriented menus. It is therefore possible to effectively prevent safety relevant errors or incomplete functions during programming.

Only the addresses of the inputs and outputs involved (or flags) need to be entered in the menus in addition to explanatory texts if required.

Reconfirmation and acceptance test

In order to save the trouble of a detailed acceptance test, the ESALAN Wireless Systems provide a special safety-related routine, i.e. before initialisation an applications program must first be read back and confirmed. The remaining acceptance test is then only restricted to checking the correct wiring. By contrast, it is no longer necessary to check the logical functionalities within the framework of an acceptance test.

Visualisation and diagnosis

In addition to the programming functions, there are many system-inherent visualisation and diagnostic facilities available via the RS 232 interface via which any faults in the control sequence and in the connected periphery can be localised and eliminated quickly and easily.

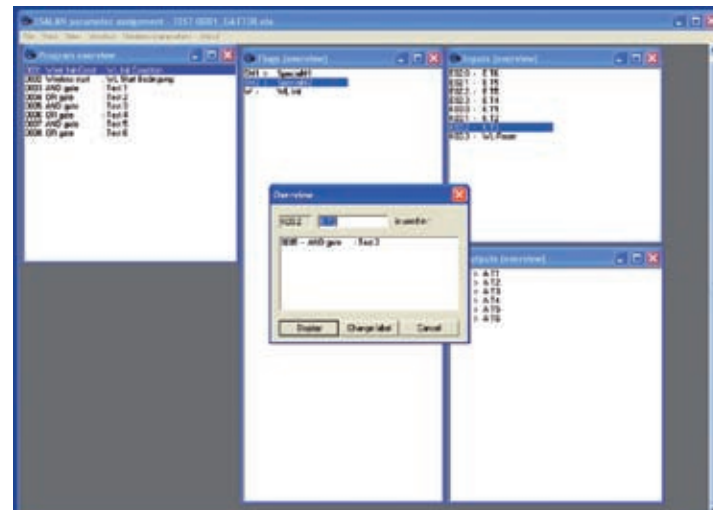

Example of the system-inherent visualisation software (here storage of the last 512 I/O changes)

Programming menus

When programming ESALAN Wireless Systems a distinction is made between obligatory and application-related menus.

The following menus are **obligatory**:

- 1) Initialisation conditions
- 2) System start.

The following menus are **application-related menus**:

- 3) EMERGENCY STOP
- 4) Enabling mode
- 5) Enabling mode + movement
- 6) Logical gates.

In respect of 1: initialisation conditions

Logical conditions are fixed in the initialisation conditions menu which must externally exist on the part of the machine control system and which must be met if an ESALAN Wireless System is to be operated. The pre-assigned input "W" means that the radio link must be in stand-by mode (refer to loc. cit.).

4 discrete inputs in the analysis and control device are available to program the initialisation conditions. An appropriate operating mode selection is typical. Depending on application additional (also negated) conditions may be possible.

The "initialisation conditions" menu generates the special flag SM1.

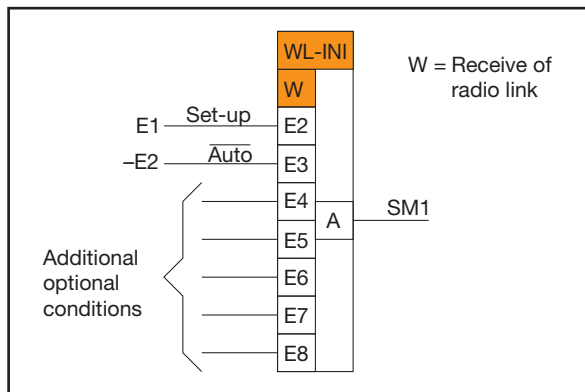
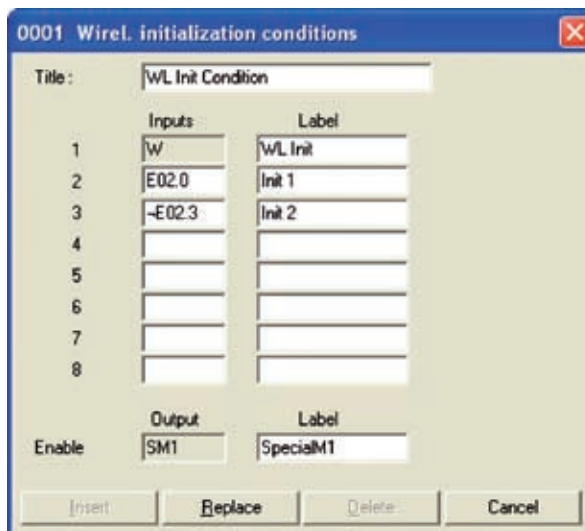

Read back menu, "initialisation conditions"

**In respect of 2:
System start**

Using the “system start” menu additional conditions are fixed which belong to the operational readiness of an ESALAN Wireless System. In addition to the flag SM1, this applies in particular to the START signal (refer to loc. cit.) which can be generated both by a button in the mobile control housing or externally (by an input in the analysis and control device). It closes the selected safety enabling paths for the EMERGENCY STOP or RELIABLE STOP functions and facilitates the transmission of movement signals.

By assignment of the “additional conditions” input, possibly in connection with flags, additional logical conditions can be programmed: for example, the check-back contact of an actor or similar.

An AUTOMATIC start is also possible, however, if the requirements of EN 60204-1 have already been observed.

The “system start” menu generates the special identifier SM2.

Information:

The flags SM1 and SM2 are automatically processed in all menus including the application-specific menus, i.e. if the respective input conditions are “infringed” there is a safety-oriented system shutdown or a system inhibition. In this respect, it is not necessary to directly program the EMERGENCY STOP or RELIABLE STOP signal of enabling switches because an interruption in the radio link automatically deletes the SM flags.

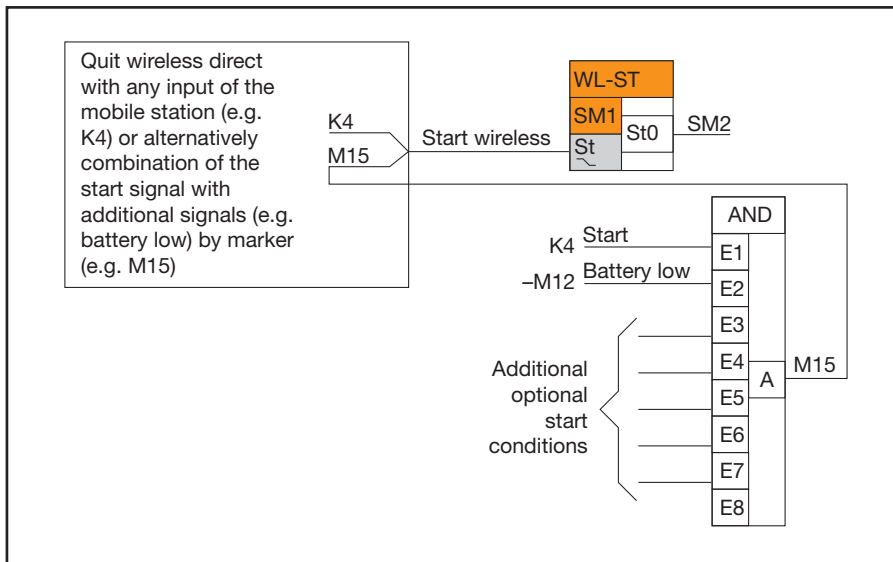
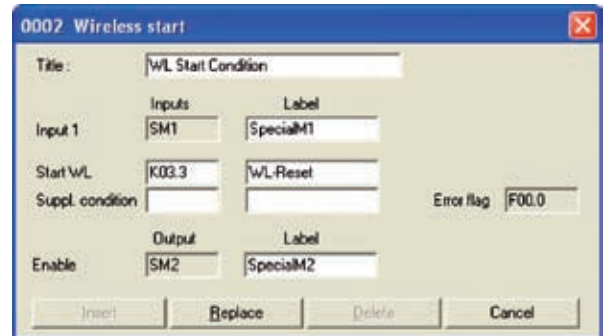

Read back menu “wireless start”

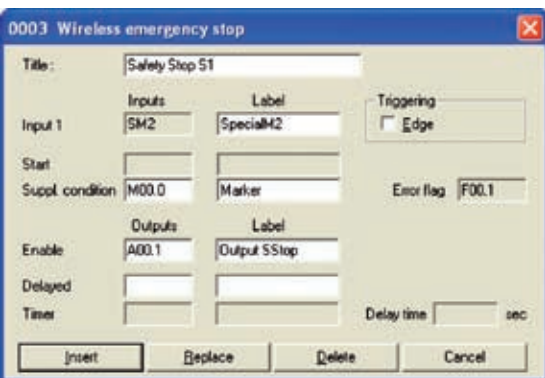

In respect of 3, 4 and 5 – SAFETY-STOP/ enabling mode

The feature of generating and signal processing of the special flags SM1 and SM 2 in the obligatory menu (refer to pages 17/18) has the advantage that no inputs need to be programmed in the **SAFETY-STOP** and in the menu for the **enabling mode** for the corresponding safety-oriented OFF signals. It may be necessary to program additional START and additional conditions and the outputs to be triggered.

Outputs

Outputs can be executed as enabling paths with STOP 0 function (for so-called uncontrolled stop) and as time-delayed STOP 1 enabling paths for so-called controlled stopping by assigning the additional programming fields accordingly (refer also to EN 60204-1 Item 9.2.2).

In respect of 4 and 5 – enabling mode

The ESALAN Wireless System in enabling mode works on the basis of 3-step enabling switches where step 1 = OFF (operational), step 2 = ON (enabling mode), step 3 = RELIABLE STOP (STOP with EMERGENCY STOP or effect comparable to an EMERGENCY STOP).

In respect of 4 – enabling mode



Attention:

Using an enabling switch alone, no hazardous movements may usually be executed (refer to EN 60204-1 Item 9.2.5.8).

This menu is conceived as a “stand alone” for special cases only.

Special cases could be, for example, inching duty or enabling mode with a second signal (triggering a movement) which is generated in a different operating field and read in via an input of the analysis and control device. In this case, the enabling input is to be assigned with a flag generated in an upstream AND gate:

For example, “signal ON enabling switch” and “movement signal E.xx signal”.

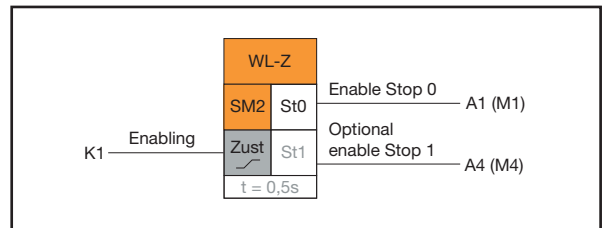
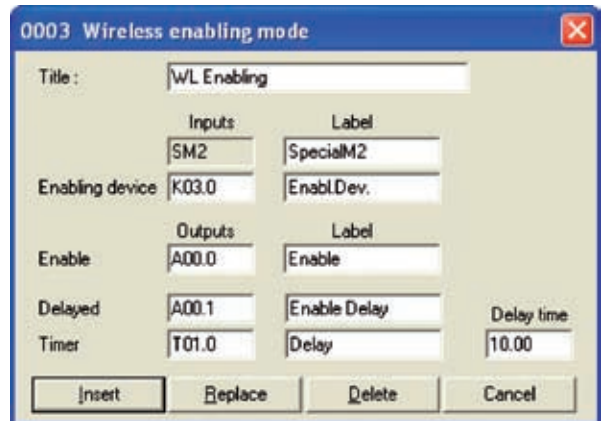

Read back menu “Wireless Enabling Mode”

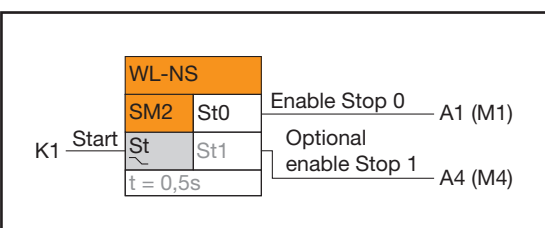

Read back menu
“Wireless EMERGENCY-STOP”

In respect of 5 – enabling and movement

The classic understanding of the function of a 3-step enabling switch as described in EN 60204-1 is shown in this menu in which an AND operation is realised between the preparing enabling signal and a further movement signal and led to an output or flag to be triggered.

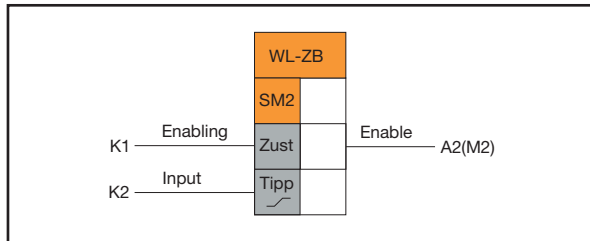
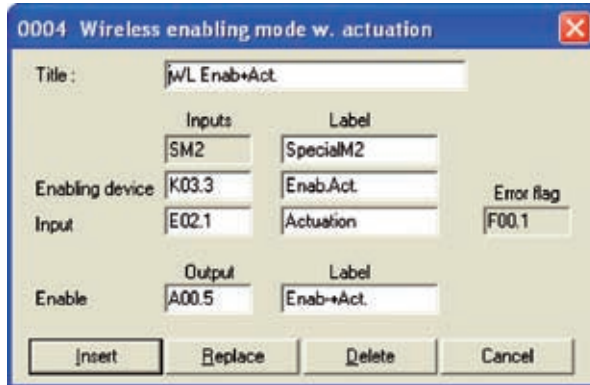

Read back menu "Wireless Enabling and Movement "

In respect of 6 – gates

Logical operations by means of AND, NOT AND, OR or NOR logic can be shown in the gate menu.

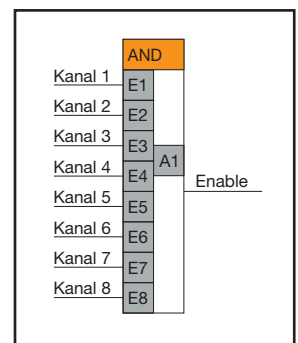
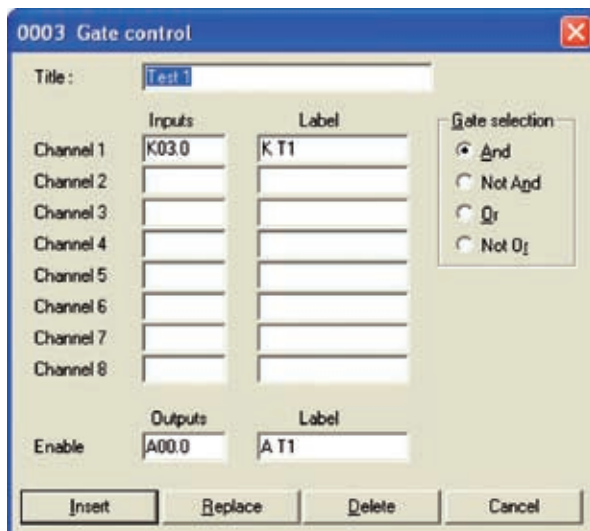

Read back menu "Wireless gate"

Activating the system

A distinction is to be made in ESALAN Wireless Systems between the following operational states of the hardware:

1. Inactive state
2. Stand-by mode
3. Active state
4. Operational readiness

In respect of 1:

Inactive state

The system (= delivered state) is in an inactive state (no radio signals are transferred), i.e. the storage battery supply in the mobile control housing is interrupted). The sliding switch ON/OFF is in the OFF position.

ON	OFF

Information:

Apart from the self-discharge there is no consumption from the storage battery charge. We therefore recommend that the sliding switch be reset to the OFF position at the end of the radio operation.

Information:

The system is similarly inactive after a safety function has been requested for example after the actuation of an EMERGENCY STOP control device.

In respect of 2:

Stand-by mode

The system is in a stand-by mode, i.e. radio signals are transmitted but without triggering inputs in the analysis and control device. The sliding switch ON/OFF is in ON position (EMERGENCY STOP control device or enabling switches are not actuated).

ON	OFF

In respect of 3: Active state

The system is active after a deliberate START signal. The START signal is given preferably via a button in the mobile control device; alternatively in the stationary operating panel. The signal of this reset, switch on or restart signal, depending on terminology used, is processed with trailing edge detection and in accordance with control category to EN 954-1. The safety function of EMERGENCY STOP control devices or enabling switches is available.

Information:

“Trailing edge” or “edge detection” means that it is not the rising edge (if a button is actuated) that generates the start signal but the trailing edge (after releasing the button). The analysis of the trailing edge or edge detection is an additional safety measure before an unexpected restart in the case of a manipulated or defective button.

Information:

The control device triggering the initialisation signal is provided exclusively for the transmission of operational signals.

In respect of 4:

Operational readiness

The system is ready for operation i.e. useful signals can be transmitted in the framework of the safety messages.

Information:

The operational readiness of the system requires all other initialisation conditions to be satisfied (refer to pages 17/18).

